

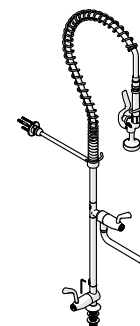

Ezy-Wash® Pre-Rinse Tapware

PRODUCT CODE:

- TF81HJS
- TF81HJP

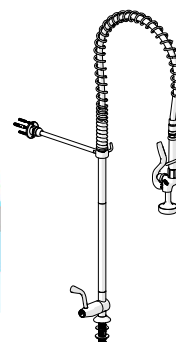

SPECIFICATIONS

- Galvin Specialised recommends the installation of strainers and pressure reducing valves prior to installing the pre-rinse unit to ensure clean consistent water supply. Debris or poor water quality could cause the trigger to seize or fail to seal.
- This pre-rinse unit has a 6 star WELS rating, the Pot Filler attachments are 0 star to allow fast pot filling.

TECHNICAL DATA

Inlet		½" BSP – Male
Outlet	TF81HJS	Trigger Spray
	TF81HJP	Trigger Spray & Pot Filler
Headworks	TF81HJS	Jumper Valve
	TF81HJP	Jumper Valve
Working Pressure Range (kPa)	Min	100
	Max	500
Working Temperature Range (°C)	Min	5
	Max	65
Nominal Flow Rate (LPM)	TF81HJS	3.5
	TF81HJP	15
Finish		Chrome

NOTE: Galvin Specialised continually strives to improve their products. Specifications may change without notice. Higher temperature or pressures could result in premature failure and void the manufacturer's warranty.

TOOLS REQUIRED

- Adjustable spanner
- Hex key
- Power drill

PRE-INSTALLATION

Body:

- If the mounting hole does not already exist, mark out and drill the hole in the bench, as shown.
- This model is a single inlet unit requiring a hole diameter of 23 to 26mm. Ensure 70mm minimum between wall and hole center as shown "A".
- Maximum bench thickness is 50mm.

Wall Bracket:

- Mark out the three (3) holes for mounting the wall bracket assembly at a height of between 430mm min - 520mm max directly up from the bench. Cut out or drill as shown in the image. (Supplied fasteners may not be suitable for the mounting surface. If this is the case, suitable fasteners will need to be sourced by the installer)

Note: We recommend the wall bracket is installed at the maximum of 520mm. The wall bracket can be mounted lower at a height of up to 90mm below the circlip. However, the further it is mounted away from the circlip, the more the stability of the unit is compromised.

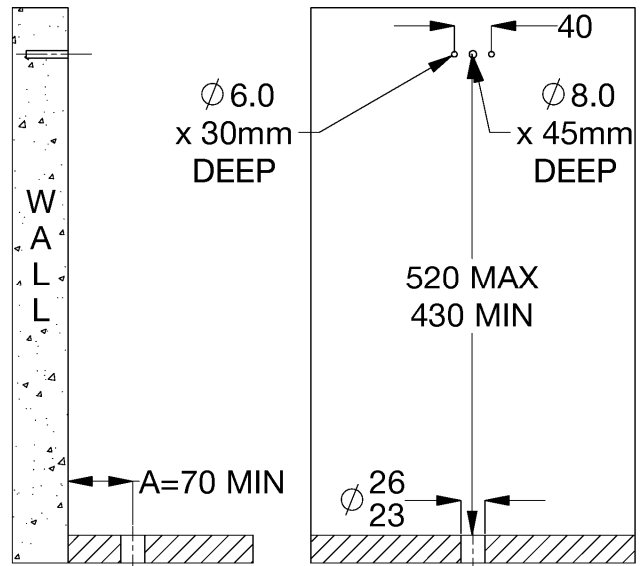

MOUNTING DETAILS

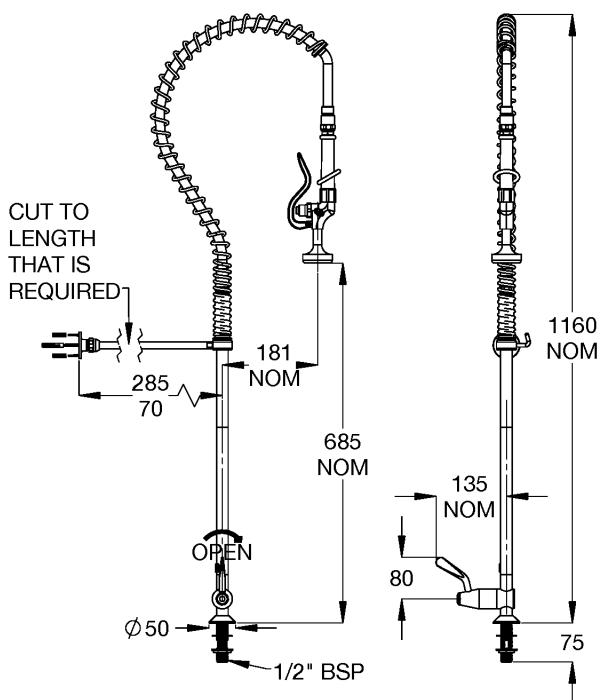

TF81HJS - Assembly

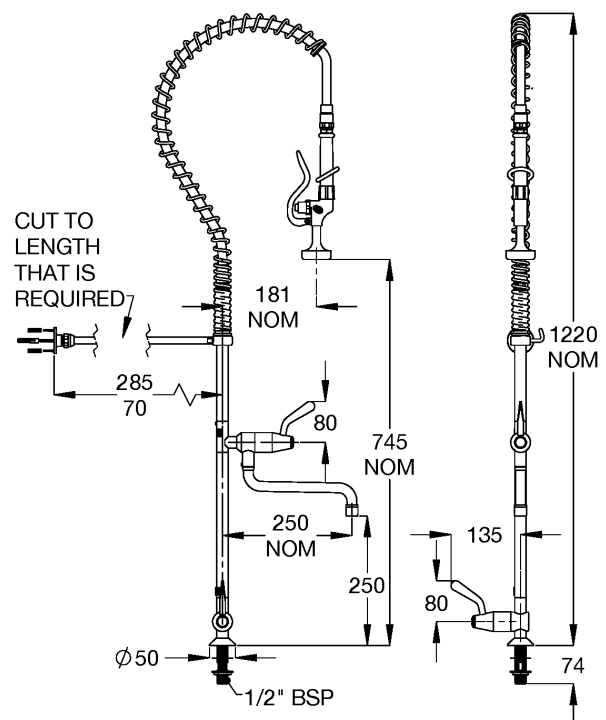

TF81HJP - Assembly

INSTALLATION

INSTALLATION COMPLIANCE: Galvin Specialised products must be installed in accordance with these installation instructions and in accordance with AS/NZS 3500, the PCA and your local regulatory requirements. Water and/or electrical supply conditions must also comply to the applicable national and/or state standards. Failing to comply with these provisions shall void the product warranty and may affect the performance of the product.

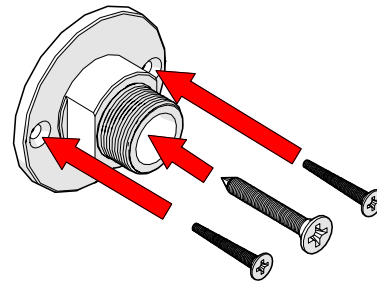
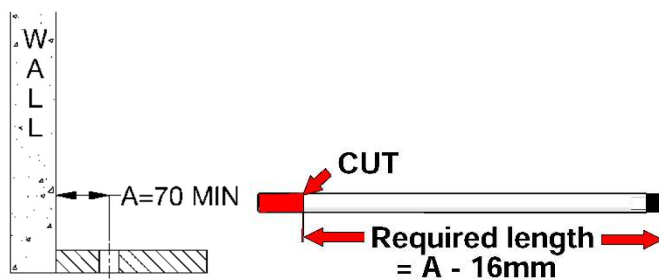

1. Measure and cut support rod

- Measure the distance between the wall mounting surface and the centre line of the drilled hole in the bench/trough (dimension “A”).
- Take dimensions “A” and subtract 16mm. This is the required length of the support rod (**Required support rod length = A-16mm**).
- Cut the support rod accordingly; ensure the threaded end is **NOT** cut off.

Note: Distance “A” must be no less than 70mm.
The support rod length can be 70mm min. to 285mm max. (If it is more than 285mm, an extension support rod must be purchased)

2. Fit wall bracket

- Secure the wall bracket to the wall.
- Supplied fasteners may not be suitable for the mounting surface. If this is the case, suitable fasteners will need to be sourced.

Note: The wall bracket must be mounted with three screws for stability and strength. This is critical and failure to do this may void the warranty.

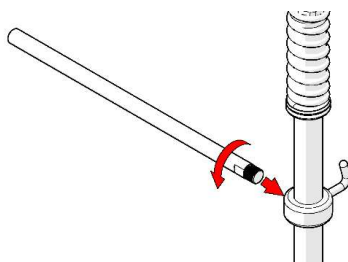

3. Fit support rod

- If pot filler kit (TF81HJP) has been purchased, it must be attached to the pre-rinse unit prior to fitting the support rod to the riser. Refer to the installation instruction supplied with the pot filler.
- Screw support rod into the riser hook and ensure it is not fully tightened.

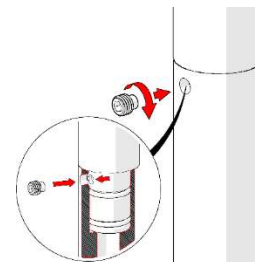

4. Fit upper riser to lower riser

- Remove protective cap from upper riser spindle.
- Fit the upper riser to the lower riser, ensure the sealing o-rings are inside the spindle.
- Tighten with new supplied grub screw.
- **It is critical that the grub screw point locates accurately into hole recess of mating part. Failure to do so may result in damage and/or failure of the unit.**

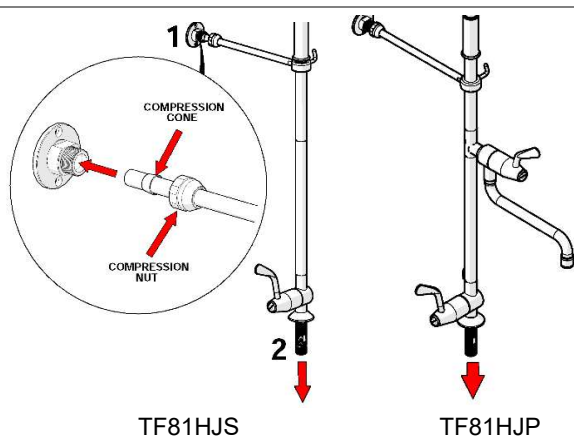

TF81HJS

TF81HJP

5. Fit pre-rinse riser assembly

1. Fit compression nut to support rod, followed by the compression cone and locate the support rod into wall bracket.
2. Fit the pre-rinse riser assembly through the drilled hole on the bench.

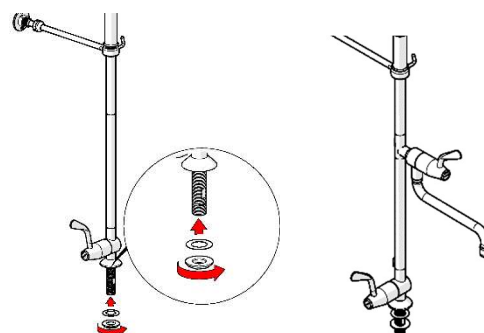

TF80H-S

TF80HJP

6. Secure pre-rinse assembly

- Secure pre-rinse assembly with the supplied flanged back nut; ensure the sealing rubber washer is placed underneath the pre-rinse body flange.

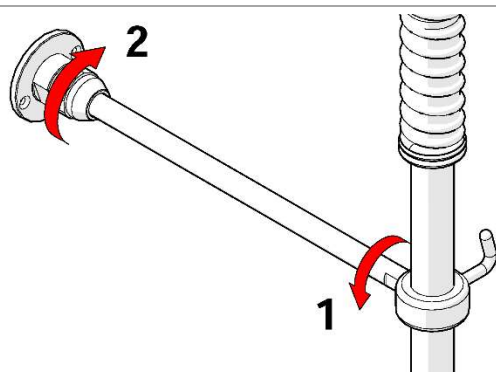

7. Secure support rod

1. Fasten support rod securely against riser.
2. Tighten compression nut on wall bracket to secure the support rod. The rod is now rigid.

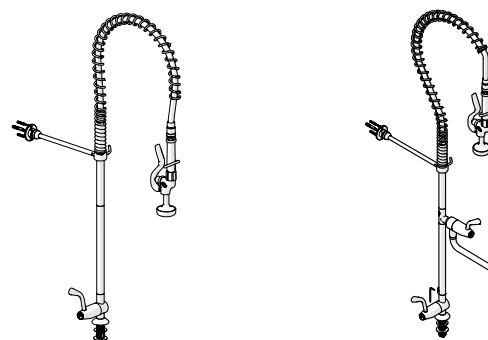

TF81HJS

TF81HJP

8. Test unit

- Once all fittings have been tightened securely, connect the unit to the mains water.
- Turn on water and test the unit for any leaks.

WARNINGS

 For optimum performance it is recommended that the isolation or mains taps are turned off whilst the unit is not in use (overnight etc.), so that the unit is not under mains pressure when unsupervised. Flood damage may occur if a failure occurs whilst the unit is under mains pressure (warranty is void in this instance).

 Galvin Specialised recommends that the handpiece is periodically serviced by a qualified plumber.

 **IMPORTANT:**

To seal the hose this unit uses Loctite 577 which is a thread sealant approved for use with potable water (AS/NZS 4020). If hose is to be removed for maintenance purposes, reseal the joints with Loctite 577, or an equivalent sealant compliant with AS/NZS 4020. Do not use thread tape to seal the hose connections, as this may cause the hose nut to become loosened over time and leak.

WARRANTY

The warranty set forth herein is given expressly and is the only warranty given by the Galvin Engineering Pty Ltd. With respect to the product, Galvin Engineering Pty Ltd makes no other warranties, express or implied. Galvin Engineering Pty. Ltd. hereby specifically disclaims all other warranties, express or implied, including but not limited to the implied warranties of merchantability and fitness for a particular purpose.

Galvin Engineering Pty Ltd products are covered under our manufacturer's warranty available for download from www.galvinengineering.com.au Galvin Engineering Pty Ltd expressly warrants that the product is free from operational defects in workmanship and materials for the warranty period as shown on the schedule in the manufacturer's warranty. During the warranty period, Galvin Engineering will replace or repair any defective products manufactured by Galvin Engineering without charge, so long as the terms of the Manufacturer's warranty are complied with.

The remedy described in the first paragraph of this warranty shall constitute the sole and exclusive remedy for breach of warranty, and Galvin Engineering Pty Ltd shall not be responsible for any incidental, special or consequential damages, including without limitation, lost profits or the cost of repairing or replacing other property which is damaged if this product does not work properly, other costs resulting from labour charges, delays, vandalism, negligence, fouling caused by foreign material, damage from adverse water conditions, chemical, electrical or any other circumstances over which Galvin Engineering has no control. This warranty shall be invalidated by any abuse, misuse, misapplication, improper installation or improper maintenance or alteration of the product

